

ANDES EcoDesign

PANADERO



MEASURES

DIMENSIONS H x W x D	850x468x409 mm
GROSS/NET WEIGHT	118/100 kg
FIREWOOD ENTRANCE	290x360 mm
SMOKE FLUE	Ø 150-153 mm Top

CHARACTERISTICS

STEEL BODY SHEET	5 mm
NOMINAL HEAT OUTPUT	7,5 KW
EFFICIENCY	81,3%
CO EMISSIONS	0,04%
HEAT RESISTANT PAINT	800°C
VITRO-CERAMIC GLASS RESISTANCE	750°C

EAN 8426964185003
REF. PANADERO 18500

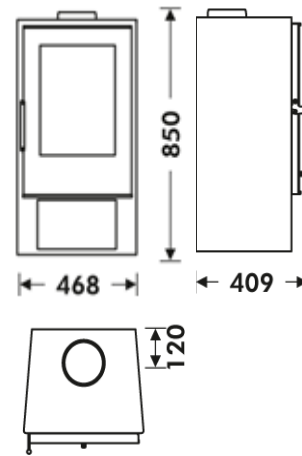

PLUS PRODUCT

ECODESIGN 2022

HERMETIC



EXTERNAL AIR INTAKE



VERMICULITE INSIDE



SERIGRAPHED GLASS



WOOD LOG STORE



HEATING VOLUME



AIR-WASH GLASS CLEANING SYSTEM



TRIPLE COMBUSTION



WOOD LOGS 40 CM



BImSchV2



ANDES