

# OVAL EcoDesign

# PANADERO

## MEASURES

DIMENSIONS H x W x D	1008x605x490 mm
GROSS/NET WEIGHT	142/131 kg
FIREWOOD ENTRANCE	355x440 mm
SMOKE FLUE	Ø 150-153 mm Top

## CHARACTERISTICS

CAST IRON GRILL	
NOMINAL HEAT OUTPUT	8,7 KW
EFFICIENCY	80,7%
CO EMISSIONS	0,03%
HEAT RESISTANT PAINT	800°C
VITRO-CERAMIC GLASS RESISTANCE	750°C

EAN 8426964183009  
REF. PANADERO 18300

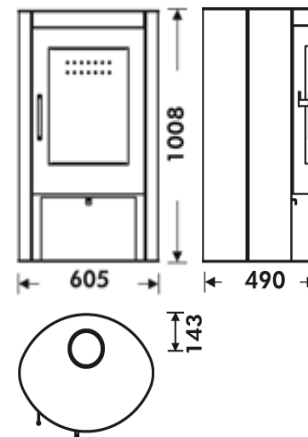

## PLUS PRODUCT

### ECODESIGN 2022

#### HERMETIC



**EXTERNAL AIR INTAKE**



VERMICULITE INSIDE



DOUBLE STEEL BODY SHEET 4 + 2,5 MM



WOOD LOG STORE



WOOD LOGS 50 CM



HEATING VOLUME



AIR-WASH GLASS CLEANING SYSTEM



TRIPLE COMBUSTION



**A+**



**BImSchV2**



OVAL